

PARTS LIST			
ITEM No	DESCRIPTION	CODE	QUANTITY
1	ENGINE BRIGGS & STRATTON 9 PLUS	7887400066	1
2	WATER SLINGER	9402200051	1
3	SHAFT SLEEVE	8037800041	1
4	BACK PLATE	9510300021	1
5	MECHANICAL SEAL TYPE 6 - 3/4"	7008300051	1
6	BACK PLATE GASKET	9510400043	1
7	IMPELLER	9510900021	1
8	VOLUTE	9510200021	1
9	VOLUTE GASKET	9510500051	1
10	CASING	9510100021	1
11	WEIGHT CHECK VALVE	7102900021	1
12	CHECK VALVE GASKET	9510700043	1
13	WEIGHT CHECK VALVE	7116400021	1
14	SUCTION FLANGE	9510600021	1
15	STRAINER	7103300023	1
16	BASE	9802400046	1

THE PARTS LIST CAN BE CHANGED BY US FLUID TECH CORP. WITHOUT NOTICE

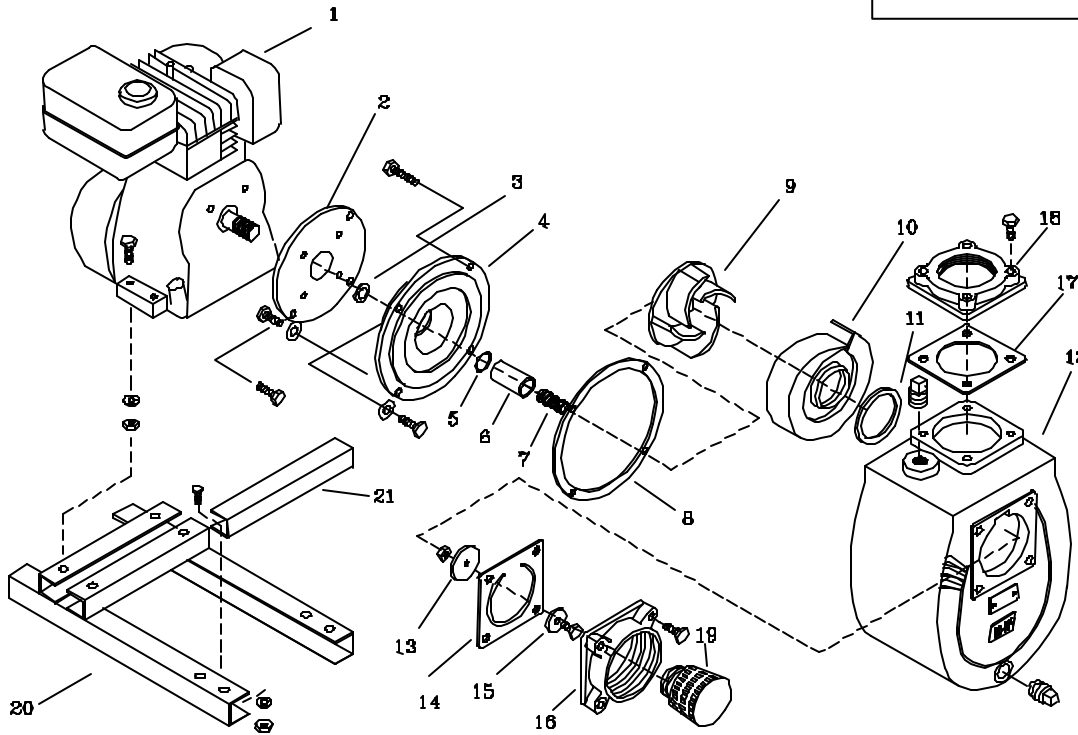

PARTS LIST				
ITEM No	DESCRIPTION	CODE	QUANTITY	
			GS 75/12I	GS 75/20I
1	ENGINE BRIGGS & STRATTON 12I	8860900066	1	
1	ENGINE BRIGGS & STRATTON 20I	8862300066		1
3	WATER SLINGER	8932800051	1	
3	WATER SLINGER	7220000051		1
4	BACK PLATE	9511100021	1	1
5	O-RING	9308000051	1	1
6	SHAFT SLEEVE	9511700041	1	
6	SHAFT SLEEVE	8725900041		1
7	MECHANICAL SEAL 1.1/4 TYPE 21	8032500051	1	1
8	BACK PLATE GASKET	9511600043	1	1
9	IMPELLER	9511300021	1	
9	IMPELLER	9511400021		1
10	VOLUTE	9511200021	1	1
11	VOLUTE GASKET	9511500051	1	1
12	CASING	9510800021	1	1
13	WEIGHT CHECK VALVE	8212600021	1	1
14	CHECK VALVE GASKET	9513600043	1	1
15	WEIGHT CHECK VALVE	7102900021	1	1
16	SUCTION FLANGE	9512200021	1	1
17	GASKET	9513700051	1	1
18	DISCHARGE FLANGE	9513400021	1	1
19	STRAINER	7308200023	1	1
20	BASE	8626700046	1	1
21	CASING SUPPORT	8623100042	1	1

THE PARTS LIST CAN BE CHANGED BY US FLUID TECH CORP. WITHOUT NOTICE

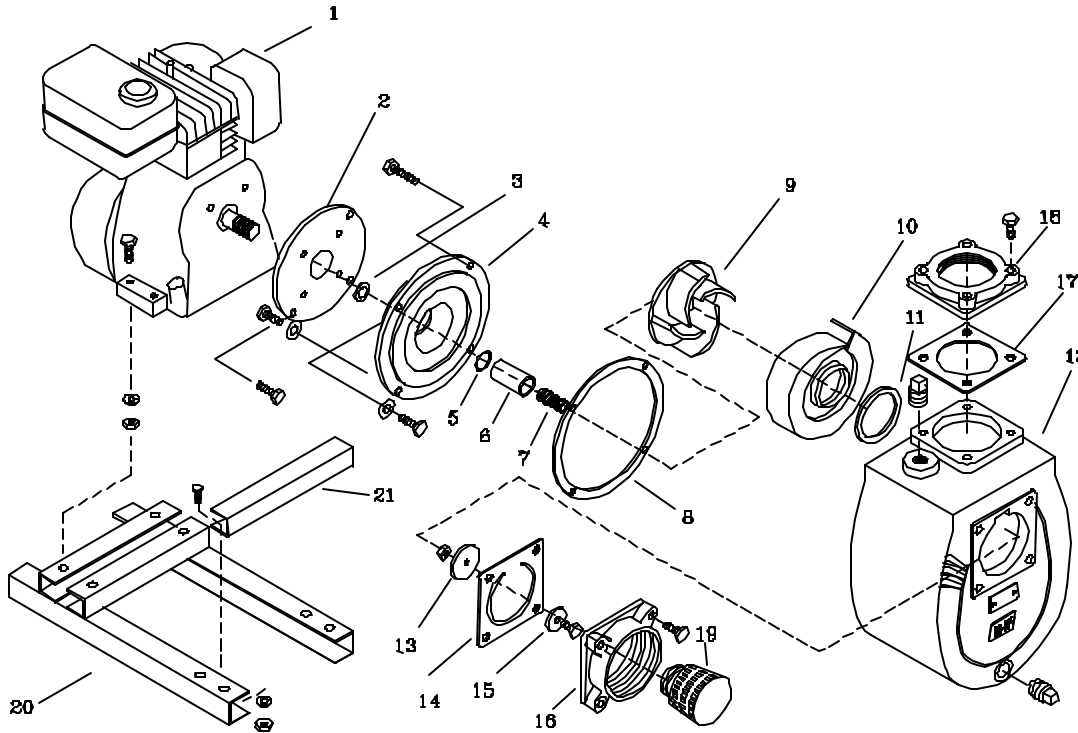

PARTS LIST				
ITEM No	DESCRIPTION	CODE	QUANTITY	
			GS 100/18V	GS 100/24V
1	ENGINE BRIGGS & STRATTON 18V	7888000066	1	
1	ENGINE BRIGGS & STRATTON 24V	8051900066		1
3	WATER SLINGER	7220000051	1	1
4	BACK PLATE	9512100021	1	1
5	O-RING	9308000051	1	1
6	SHAFT SLEEVE	8725900041	1	1
7	MECHANICAL SEAL 1.1/4 TYPE 21	8032500051	1	1
8	BACK PLATE GASKET	9512300043	1	1
9	IMPELLER	9512400021	1	
9	IMPELLER	96001A0021		1
10	VOLUTE	9514600021	1	1
11	VOLUTE GASKET	9515000051	1	1
12	CASING	9512000021	1	1
13	WEIGHT CHECK VALVE	7103000021	1	1
14	CHECK VALVE GASKET	9514800043	1	1
15	WEIGHT CHECK VALVE	7102900021	1	1
16	SUCTION FLANGE	9514400021	1	1
17	GASKET	9514900021	1	1
18	DISCHARGE FLANGE	9514500021	1	1
19	STRAINER	7009900046	1	1
20	BASE	8626700046	1	1
21	CASING SUPPORT	8636100042	1	1

THE PARTS LIST CAN BE CHANGED BY US FLUID TECH CORP. WITHOUT NOTICE

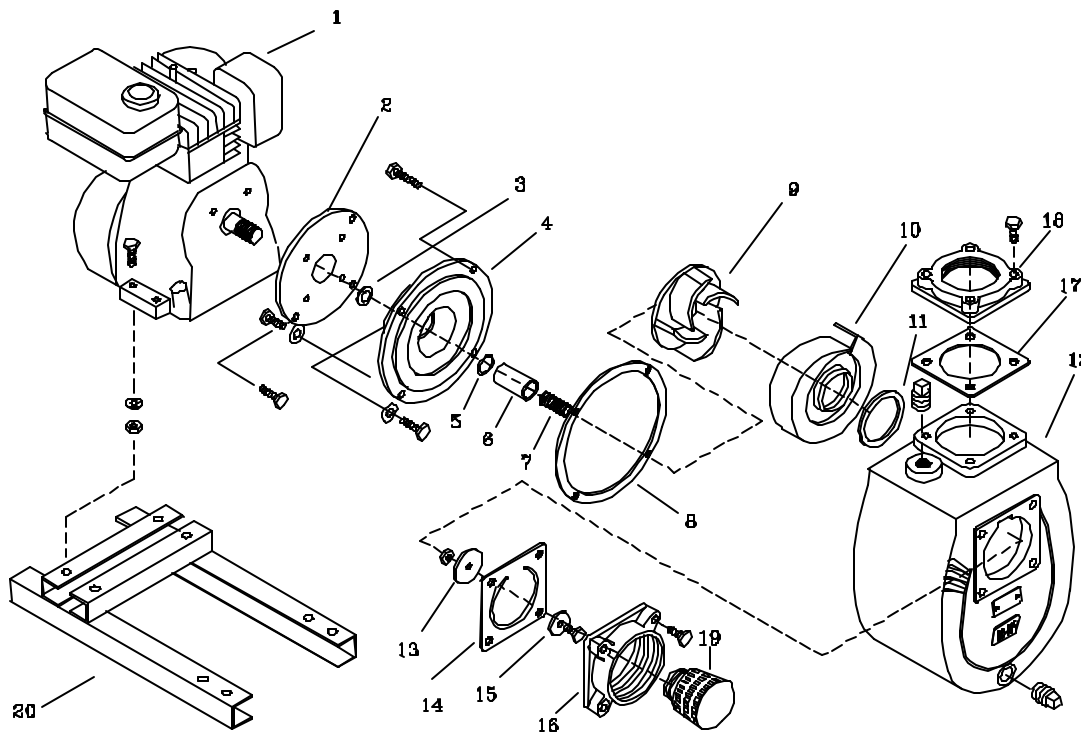

PARTS LIST

ITEM No	DESCRIPTION	CODE	QUANTITY
1	ENGINE BRIGGS & STRATTON 24V	8051900066	1
3	WATER SLINGER	7614600051	1
4	BACK PLATE	9903700021	1
5	O-RING	9308000051	1
6	SHAFT SLEEVE	8725900041	1
7	MECHANICAL SEAL 1.1/4 TYPE 21	8032500051	1
8	GASKET	9904500043	1
9	IMPELLER	0003300021	1
10	VOLUTE	9904100021	1
11	VOLUTE GASKET	9515000051	1
12	CASING	9903600021	1
13	WEIGHT CHECK VALVE	0003100046	1
14	CHECK VALVE GASKET	9904300051	1
15	WEIGHT CHECK VALVE	8212600021	1
16	SUCTION FLANGE	9903800021	1
17	GASKET	9904400051	1
18	DISCHARGE FLANGE	9904000021	1
19	STRAINER	7109100046	1
20	BASE	0002300046	1

THE PARTS LIST CAN BE CHANGED BY US FLUID TECH CORP. WITHOUT NOTICE