



OWNERS MANUAL

Duralum Trash Series

CENTRIFUGAL SELF-PRIMING PUMPS - TYPE TRASH
DIE CAST ALUMINUM - EPOXY COATED



IMPORTANT

Read these instructions before
installing your new pump



Address: 20871 Johnson Street
Unit 107
Pembroke Pines, FL 33029
Telephone: (954) 392-0208
Fax: (954) 392-0209
e-mail: info@usfluid.com

015060PU

Copyright 2001 by U.S. Fluid Tech Corp.

THIS MANUAL CONTAINS THE NECESSARY INSTRUCTIONS
FOR THE PROPER ASSEMBLY, INSTALLATION AND
MAINTENANCE OF THE PUMPS.

TABLE OF CONTENTS

1. Unpacking the equipment.....	1
2. Planning the installation	1
3. Installation	2
4. Priming	4
5. Before starting.....	4
6. Storage.....	6
7. Maintenance	6
8. Troubleshooting.....	7
9. Assembly process.....	8
10. Parts list	11

1. UNPACKING THE EQUIPMENT



Check the contents of each box for missing items and for damage that may have occurred during shipment. Report any loss and damage at once.

2. PLANNING THE INSTALLATION



The pump should be located on a level firm foundation, putting it as near as possible to the level of the liquid that is to be pumped, but never higher than 20 feet.



Don't forget to read the engine manual, before starting the unit.

Pump location

Place the pump on a firm place that will absorb any vibration and provide a permanent and rigid support. This place should allow appropriate ventilation for the engine.

Suction and discharge hoses

Install a (if is necessary) 90° elbow (not supplied) on the pump's discharge and then attach the quick connectors.

The suction and discharge should have a male adapter to connect the hose. The fittings should have the same diameter as the suction diameter.

Use Teflon tape to prevent leakage on the joins.

Connect the hose couplings to the suction and discharge fittings. Be sure to use strongly reinforced hose on the suction side. Tighten hose couplings firmly. Hose or pipes should be supported independently and not carried by the pump.

3. INSTALLATION

Connecting suction lift

The suction hose or pipe must be kept free of air leaks, particularly when the suction line is long and the static suction is high. It is advisable to keep the suction hose short, setting the pump as near as possible to the liquid.

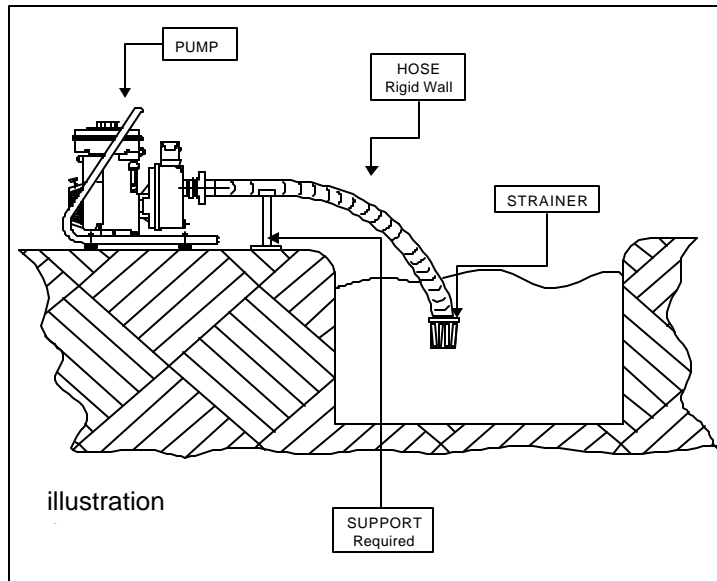

- ✓ Use pipe, or reinforced hose to make suction connections. Hose must have sufficient strength to resist collapsing under the atmospheric pressure.
- ✓ The pump does not need foot valve. Use a strainer to prevent solids from being drawn into the pump and clog the pump impeller.
- ✓ Align properly pipes and fittings.
- ✓ Independently support pipes and fittings to reduce strain on the pump casing.
- ✓ Use Teflon tape on the joins to prevent leakage.
- ✓ Suction area of the strainer must be at least four times the suction pipe area.
- ✓ Suction pipes, hoses or fittings should have a diameter equal to the pump suction diameter.

- Suction hose sloping downward to pump inlet will trap air which will reduce performance and may cause pump to lose priming.
- Suction pipe or hose that is undersize will create excess friction losses that may cause cavitation and reduction of pump performance.
- Excess fittings and bends in suction line results in trapped air, reduced performance and high friction losses.



4. PRIMING

The pump must be primed before starting. Follow the instructions given below:

- Open the filling plug that is on the elbow and fill the pump casing. To fill the pump casing it is necessary from one to 2 gallons of water (depending on the pump model).
- When there is no plug in the elbow, fill the casing through the discharge connector. It may be necessary to disconnect the quick connect of the discharge hose to fill the casing.
- Fill the pump with water completely to force all air out.
- Slowly rotate the shaft to allow any air trapped in the impeller to escape.
- When all air has been forced out of the pump, replace the filling plug. Use pipe joint compound on plug threads and tighten as necessary to prevent leakage.
- Remember the pump is self priming only when the casing pump is filled. It will prime and reprime itself without refilling. Refilling is necessary only if pump has been drained or if the fluid has been lost.
- **Priming time:** With a suction lift from 5 to 10ft. the pump should discharge the liquid in less than one minute. A suction lift of 20 ft. (at sea level) should not require more than 2 minutes for initial prime. If pumping does not start within this time, shut off engine and check carefully to find the difficulty. (Refer to "Troubleshooting Section").

5. BEFORE STARTING



- *Do not operate the pump without liquid as serious damage could occur. Many pump components depend upon the liquid for lubrication.*

- *Consult the maintenance section of this manual for lubrication instructions before operating the pump.*

1. A suction strainer should be attached to the suction hose or pipe to prevent large solids to damage the impeller. Keep the strainer clean, and if possible, lift it away from the sediment.
2. Fill the engine crankcase with oil as specified in the engine manual.
3. Fill the fuel tank with regular gasoline.

START UP

Start the engine, following instructions in the engine manual.

RUNNING THE ENGINE

High suction lifts, require high engine speed and low lifts require lower engine speed. Therefore, on shallow lifts or when there is little liquid to pump, save fuel by reducing the engine's speed (See engine manual).



- *The engine must be filled with oil before starting, don't forget to read engine manual for this procedure.*
- *Do not use pump in explosive atmosphere. Do not pump volatile or flammable liquids.*
- ***Draining:** During freezing weather, be sure to drain pump when it is not in use.*

6. STORAGE



Unscrew the drain plug to allow all the water in the pump to get out. Make sure the pump is empty before replacing the drain plug.

Storage: When pump is out of service for long periods, drain it and store in a dry, well ventilated room. Pull engine hard against compression so valves will be sealed (Never run pump dry for more than half a minute or shaft seal may be damaged).

Read the engine storage instructions in the engine manual.

7. MAINTENANCE

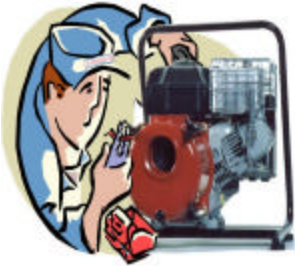

The self priming Duralum Trash Series pumps are designed to operate efficiently for years, but like all other machinery, they require regular inspection and care.

The purpose of regular inspection and maintenance is to prevent breakdowns and to obtain the longest service life possible.

- This pump does not need external lubrication, because the internal parts are lubricated by the liquid that is being pumped.
- You should periodically inspect the complete installation to find any leaks, or other problems.
- You should clean the whole unit periodically.
- If you notice any internal noise, remove the casing to inspect the internal pump parts if you found any damage, you should consult immediately with the technical service.

- Protect engine against heat, dirt and moisture. Protect the engine from the sun, provide ample cross ventilation. Keep engine vents and surrounding area clean. Avoid sweeping or stirring up dust near the engine while it is running. Avoid storing (or spilling) pool chemicals near the engine. Provide protection from rain, snow, lawn sprinklers etc. Avoid splashing water near the engine.



The pump can be used to move mixtures of water and light acids (low corrosive acids), each time that you used the pump in this application (for example to wash swimming pools) You should wash it (internally and externally) with pressure fresh water.

8. TROUBLESHOOTING



If difficulties are experienced, in the majority of cases they can be traced to well-known causes.

We suggest you check these points first to save needless expense.

If the pump fails to prime:

- Make sure that pump casing is full of cool liquid.
- If difficulty continues, remove suction pipe or hose, start engine and hold a flat and thick piece of rubber, or other suitable material, against the suction inlet. If the pump develops a strong pull against the material, the problem is not in the pump. If there is no pull, the shaft seal may need to be replaced.



The vacuum developed by the pump could damage the flat piece of rubber. Shut off the pump quickly after the test has been done to prevent any damage.

- Examine suction hose or pipe connections. Air leaks in the suction line and connections to pump are the most frequent causes of priming trouble. Use new gasket in hose coupling. New couplings sometimes require two gaskets. Hose lining may also become loose and clog the hose.
- Keep pump as close to the level of the liquid being pumped. It will give best performance on suction lifts less than 15ft. It is not guaranteed to handle any lift over 20ft at sea level.
- Be sure strainer is not clogged.
- There are no parts or valves to become clogged or out of adjustment. The only requirement is that the pump case is full of liquid.
- Keep your pump unit clean and properly serviced. Care in this respect will repay in many years of trouble-free operation.

9. ASSEMBLY PROCESS

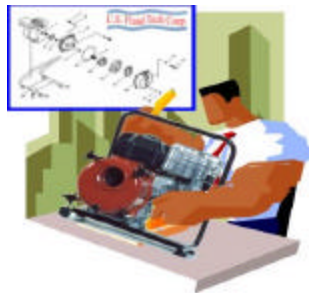

• BEFORE ASSEMBLING (only for pump ends).

1. Check that engine flange and shaft measures are in accordance with diameter and threaded shaft.
2. All units are partially assembled. In the box there are bags with the necessary screws and accessories to complete the assembly.

3. When opening the box be sure that the parts do not show evidence of damage during transportation.
4. After unpacking the units, all the parts should be placed on a smooth, dry and clean surface.
5. Read carefully all instructions given below before assembling the unit.

• ALL MODELS

1. Place the engine (1) with the shaft up vertically. Clean the matching surfaces, clean the engine shaft and coat its surface with a small amount of grease.
2. Put the water slinger (3) on the shaft as close as possible to the engine oil seal.
3. Place the gasket (2) on the machined surface of the engine flange, For easier fitting, put some grease around the gasket holes.
4. Place the ceramic part of the mechanical seal (9) on the back plate (6) so that the white shiny surface is visible. To make this operation easier, put oil in the elastic ring of the seal. Do not hit or damage in any way the ceramic part of the seal. Insert the seal using finger pressure only.
5. Tighten the four bronze screws (4) and bronze washer (5) to the back plate treaded holes (6), as shown in the parts list drawing.
6. Place the back plate (6) on the engine, checking a close fit between the back plate and engine flange. Before fixing the parts, be sure that the position of the back plate is correct with the drain outlet down.
7. Tighten the screws and locker washers on, to fix the back plate to the engine flange. Tighten the screws well and evenly in an "X" sequence.
8. Clean the shaft sleeve surface (7). Place the rotating part of the mechanical seal (9) on the shaft sleeve. To make this operation easier, put oil in the elastic ring of the mechanical seal.
9. Then, put this assembly (Shaft sleeve-Rotating part) on the engine shaft. Check for a close fit between the white shiny surface of the ceramic part and the carbon ring of the mechanical seal.

10. Fit the impeller (10) on the shaft, with a clockwise rotation and be sure that the impeller is screwed up to the shaft sleeve.
11. After cleaning the surfaces thoroughly, place the oring (8) in the circular groove of the back plate.
12. Place the volute (11) on the back plate, fitting the back plate pins through the volute holes.
13. Place the check valve (12) properly so as to have a perfect fit between the check valve and volute.
14. Place the casing (13) on the back plate.
15. Tighten the casing (13) with the washers and the extended screws (16, 17) provided. Tighten the extended screws well and evenly in an "X" sequence.



You should tighten the extended screws evenly in an "X" sequence or a serious damage could occur in the casing or back plate .

16. Place the drain plug (15) along with gasket (14).



10. PARTS LIST

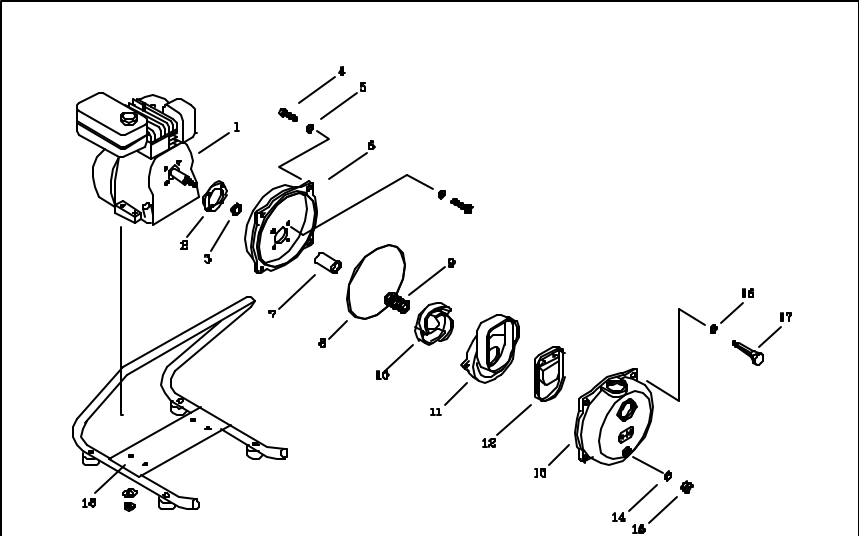

PARTS LIST		
ITEM No	DESCRIPTION	QUANTITY
1	ENGINE	1
2	GASKET	1
3	WATER SLINGER	1
4	BRONZE SCREW	4
5	BRONZE WASHER	4
6	BACK PLATE	1
7	SHAFT SLEEVE	1
8	O-RING	1
9	MECHANICAL SEAL	1
10	IMPELLER	1
11	VOLUTE	1
12	CHECK VALVE	1
13	CASING	1
14	DRAIN PLUG GASKET	1
15	DRAIN PLUG	1
16	BRONZE WASHER	4
17	EXTENDED SCREWS	4
18	BASE	1

The serial number located on the pump's nameplate, identifies the pump's model and is required for reference when ordering spare parts.